

User manual
Hydraulic Comparator
HS706



Claim

- The operating instructions are parts of the products and must be kept in the immediate vicinity of the instrument and readily accessible to skilled personnel at any time.
- Skilled personnel must have carefully read and understood the operating instructions prior to beginning any work.
- The manufacturer's liability is void in the case of any damage caused by using the product contrary to its intended use, non-compliance with these operating instructions, assignment of insufficiently qualified skilled personnel or unauthorized modifications to the instrument.
- HUAXIN reserve the rights to change the contents or form of these operating instructions at any time without prior notice having been given.

Safety information

Symbol



.....warns you against actions that can cause injury to people or damage to the instrument.



..... points out useful tips, recommendations and information for efficient and trouble-free operation.

Warning

In order to protect your products, your own and others safety, please read this manual carefully before your operation, otherwise it may cause trouble. Huaxin is not liable for any safety problems or damages caused by misuse or incorrect operation.

① Operate by professional



The system must only be operated by trained and authorised personnel who know the manual and can work according to them.

② Use the product only as specified



Any operation not included in the following instructions or outside the specifications must not be attempted.

③ Please use non-damage goods



Don't use the product if it is damaged.

④ No Disassembling

 Disassembling may cause physical injury or equipment damage. Only qualified technicians are allowed to fix the equipment. Please call our service staff for repair instruction and guidance if there would be anything wrong.

⑤ Don't calibrate water pressure gauge

 Only provide pressure for oil gauge. If you use the item to calibrate water pressure gauges, maybe water will enter into it and that couldn't generate pressure anymore. Meanwhile that may pollute the gauges under test.

⑥ Store the item with pressure

 If this equipment will be in idle for a long time, please provide pressure about 2bar and tighten the plugs. In order to avoid the air enter into the item inside, that will affect the system stability when you use it next time.

Labelling

Hua xin Instrument(Beijing)Co.,Ltd.		Manufacturer.
Model	HS706	Model.
Product	Hydraulic Comparator	Product name.
Range	(0-2500)bar	Pressure range.
No.	140126046	Serial number.
Date	2014.01	Date of manufacture.

Claim

Safety

1.Summary	1
2.Technical Specification	1
3.Components	2
4.Working principle	3
5.Operation	4
6.Troubleshooting	4
7.Maintenance	5
8.Support	5

1. Summary

HS706 Hydraulic comparator is generated pressure up to 2500bar to calibrate high pressure instruments against a standard gauge. It is fitted with hand pump which could quickly pressurize to the whole system; perfectly integrated operation of hand pump helps user to accomplish high pressure points calibration, closing Shut off valve during pre-pressurizing 150bar in order to get high pressure ranges. The lead screw adjusts the exact pressure values in the process. A specially designed transparent oil cup marks the balance of working medium. It widely calibrates pressure gauges in the laboratory.

Functions

HS706 provides pressure measurement for calibrating pressure (differential pressure) transmitter, precision pressure gauge, general pressure gauge and other pressure instruments. It can be extensively used in power, chemical, petrol, metallurgy, metering, military industry, etc.

Characteristics

- It has secondary oil filter and a settler. The waste oil can be filtered.
- Stainless steel and easy operation.
- The transparent oil cup could mark the balance of working medium.

2. Technical Specification

Model: HS706 Hydraulic comparator

Generated pressure range: (0~2500)bar

Working media: 25# transformer oil

Adjust resolution: 0.01bar (1kPa)

Material: Stainless Steel/Aluminium for body; Stainless steel for outputs; Buna-N for seals

Output interface connection: M20×1.5 Female

Package: Plywood case

Dimensions: 570L×490W×195H(mm)

Weight: 25kg

3. Components

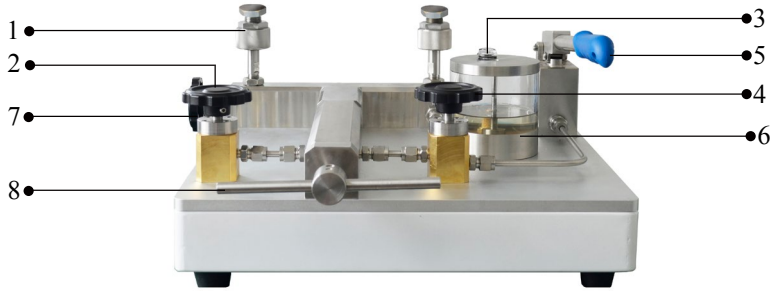

① Output

There are two outputs. one is designed for standard gauge, the other for gauge under test.

② Relieve valve

To open it anti-clockwise during pre-pressure and close it clockwise when increase pressure secondary. Open it during loop calibration.

③ Ventilation nut

Unscrew the nut before use; tighten it up during storage and transport.

④ Shut-off valve

Cut off the connection between pressure regulation system & oil cup.

⑤ Hand pump

Turn the hand pump up and down repeatedly to generate pressure. Hand pump will be realize prepressing function.

⑥ Oil cup

Store 25# transformer oil, turn the top cover anti-clockwise to change or fill oil.

⑦ Zero valve

To close it anti-clockwise during pressurizing and open it to release all pressure after finishing tests.

⑧ Lead screw

To realize the fine adjustment of pressure value. (Turning in clockwise to increase pressure).

4. Working principle

HS706 is composed of hand pump, lead screw, shut-off valve, relieve valve, zero valve, oil cup and outputs, etc. Supply pressure by hand pump, and control the shut-off valve, zero valve and relieve valve to pre-pressurize for pipeline ①. Then close relieve valve and open shut-off valve, pressurize for pipeline ② with hand pump. That can realize pressure increasing secondly. Adjust the lead screw to reach desired point more accurately.

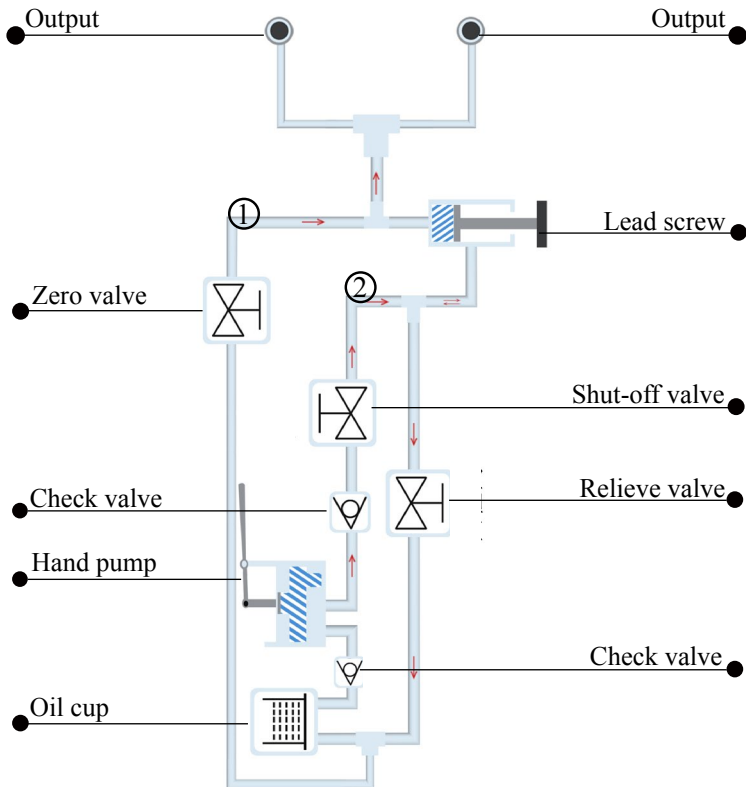

5. Operation

- A** Take pressure gauge 2500bar as example(The calibration points:0bar 500bar 1000bar 1500bar 2000bar 2500bar)
Please fill the work medium (25# transformer oil) before calibration.The oil position should be at least 2/3 of the whole oil cup.
- B** Put HS706 on the level. unscrew ventilation nut. Remove the plug of the outputs, connect the standard gauge and the gauge under test to the two output ports separately with wrenches. it must firm in place.Otherwise, it will be leakage.
- C** Rotate lead screw to its middle position.Open relieve valve anticlockwise,make sure to close shut-off valve and zero valve.
- D** Record 0bar record. Providing pressure about 150bar by turning hand pump up and down and stop pre-pressure.
- E** Close relieve valve,then open shut-off valve anti-clockwise. Increase pressure by hand pump to make value of standard gauge close to 500bar,adjust the lead screw to get exact value.
- F** Use the hand pump and lead screw to get other calibration points. Pressure rising & stabilize to 1000bar,1500bar,2000bar,2500bar in turn.meanwhile,record the data.
- G** Loop calibration:Decrease pressure by opening relieve valve slowly,and adjust the lead screw to get exact values.Record the data when the pressure stabilize on 2000bar,1500bar,1000bar,500bar and so on.
- H** Then open the zero valve and release all pressure,change gauge under test and calibrate next one.

i Remark:

- 1.Hold the lead screw,turn in and out to complete fine adjustment.
- 2.Please put on the plugs after all the tests have been finished.

NOTES:

- 1.There must be no pressure in the system when removing pressure gauge.
- 2.Replace the O-rings regularly.
- 3.The wroking media of item is oil,please don't mix any other liquid.

6. Troubleshooting

There may be some faults of HS706 mentioned below after long term use, the maintainer can analyse and eliminate problems by these methods. Make sure to release all pressure of system. It is forbidden to disassemble and repair the product with pressure.

Faults	Cause	Solution
Oil leaking	The O-ring seal is loose or damaged	Replace the O-ring
	There is large damage on the sealing faces of gauge under test	Check the sealing faces
Hand pump couldn't generate pressure	No enough medium is in oil cup	Add medium
	The O-ring seal is damaged	Replace the O-ring
	The gauge under test has huge capacity	Increase prepressing times
The pressure is instability,the standard gauge depressurized quickly	Check the instrument to make sure there is no leakage of oil.Otherwise the O-ring is damaged or there is connection loosening	Replace O-ring,or reassemble
	Pressurize without gauge under test.if the instrument doesn't leak pressure,this indicates gauge under test has problem. Otherwise there is problem with device or standard gauge.Check the standard gauge and device separately	Replace standard gauge or gauge under test

7. Maintenance

7.1.If this equipment will be in idle for a long time, please turn the lead screw clockwise till it could not move anymore, and put on the plugs. Provide pressure about 2bar,close shut-off valve,zero valve and relieve valve,then tighten the ventilation nut.

7.2.If HS706 needs to take a long distance transport, please put on all plugs to prevent leakage of oil.It is necessary to pack with plywood case.

7.3.Replace working medium regularly.

7.4.The working medium is 25#transformer oil or any oil that can be used for calibrating gauges.

8. Support

The product specifications and other information contained in this manual are subject to change without notice,if you have any questions,please call our services hotline:400 611 3558 or Tel:+86-10-62392087

HUAXIN Products series

Digital Pressure Gauge

HX601/HS108

Intelligent Pressure Calibrator

HS602

Pressure Comparator

HS700(-0.5-0.5)bar

HS701(-0.95-6)bar

HS702(-0.95-16/25)bar

HS703(-0.95-40/60)bar

HS720(0-140)bar

HS704 (0-160/250)bar

HS705/HS705A(0-600/700)bar

HS710/HS710A(0-600/700)bar

HS706(0-1600/2500)bar

Electrical Pressure Comparator

HS318L(0-600)bar 5pcs output

HS316L(0-25)bar 5pcs output

HS317L(0-60)bar 5pcs output

HS315(-0.95-0)bar 2pcs output

HS316(0-25)bar 3pcs output

HS318(0-600)bar 3pcs output

Automatic Pressure Calibrator

HS620(-0.1-1)bar,(-0.95-25)bar

Sphygomanometer Calibrator

ME01 & ME02

Temperature Calibrator

HUAXIN INSTRUMENT(BEIJING)CO.,LTD

Add:No.11,Chuangxin road,Changping,Beijing,102200,China.

E-mail:sales-huaxin@comeonhs.com/Web:<http://www.sino-instruments.com>

Tel:+86-10-62392087/Fax:+86-10-62345183